

Consumer Electronics Show:

More Reasons for Customer Demand; More Help for Fiber Deployments

Digital Rights Management problems may be on the way to solution, too

A BBP Staff Report

(Company names are in boldface the first time they are mentioned.)

We prowl the annual Consumer Electronics Show each year to report on new devices, new businesses and new marketing ideas that will soak up bandwidth. More downloads. More uploads. More ways to move massive amounts of content around a home network. New kinds of content, and new ways of categorizing and keeping track of it. The objects of our desire were not hard to find. Almost every booth, it seemed, featured wide-screen, flat-screen HDTV. Almost every newspaper article on CES 2006 featured deals among the creators of video content. Video alone can drive fiber demand; two or three channels of HDTV take 30 Mbps or more.

Looking behind and beyond the headlines and the obvious, we found excitement in the details, things of special interest to the broadband industry in general and fiber to the home in particular. Now, as never before, the consumer electronics and online content businesses depend, utterly depend, on deployment of fiber, especially fiber to the home and within the home.

Have you heard about vlogs yet, for instance? Video blogs. A company called **Serious Magic** (seriousmagic.com/products/vlogit/index.cfm) introduced a \$50 software package, Vlog It, for creating your own. Creative Labs will be bundling it with Webcams.

Then there's **ITVN**, Interactive Television Networks. Buy the set-top



ITVN's small "set-top box" is closer to the size of the Ethernet routers used by others who ride on bandwidth, such as VoIP lines. Outputs are for composite, S-video and RGB video.

box for \$99.95 and pay as little as \$4.95 a month for full-screen TV programming. At that price, you don't get much – mainly old, old movies and radio. But \$9.95 a month more gets you professional lacrosse (where else would you see it?) and \$29.95 provides 160 porn channels. The box attaches to any broadband Ethernet connection and installation should be as easy as for VoIP – with buffering needed on slower lines or bad connections (it streams at 300 to 700 kbps). See www.itvn.com.

Dozens of firms showed devices (more details below) that make home networking easier and less expensive. Their technologies allow great flex-

ibility in fiber deployment without the need for expensive structured wiring within the home – and vastly reduced costs. Some fiber deployers are faced with the absurdity of finally solving the First Mile problem (at about \$1,000 per home passed) while bumping up against the First Meter (with structured wiring, set-top boxes and service adding \$2,000 or more to the cost for each new customer).

Hollywood is certainly getting used to the idea of downloadable digital content. But if you think the moguls are talking about downloaded video to tiny iPod screens, think again. These **Apple** iPod downloads can be full-screen IPTV. There are now ways to

connect a tiny iPod to a TV or computer, or even to video eyewear that lets viewers see video on what appears to the eye to be a 40-inch screen.

Digital rights management isn't going away, however. Count on it to confound easy adoption of home networking. **Samsung's** new cell-phone-sized Helix receiver records XM Satellite radio, for instance, without having to dock the device at a computer or separate receiver. Hollywood still wants the federal government to force equipment vendors to sense a "broadcast flag" that would limit consumers' ability to record and replicate whatever they want. They were unsuccessful last spring, after a federal appeals court overturned an FCC regulation that would have mandated it.

Sony Chairman Howard Stringer said producers must improve copy protection schemes, and standardize them in a way that allows consumers to distribute content in their own homes in formats of their own choosing. The consumer outrage over Sony BMG's copyright software that exposed computers to hackers highlighted the problems content and hardware providers face, he said.

Characterizing CES as "nothing short of a revolution," Peter Chernin, president of **News Corp**, proclaimed there has never been a more exciting time for the content industry whose purpose is to connect the masses. "The content industry is ceding control to consumers and coming to terms with technology and today's landscape," he added.

Chernin also outlined issues that remain to be addressed: Interoperability, creating a regulatory environment for broadband and protecting content from theft. "We're ready to jump in with both feet, but need assurance our content will be protected."

One sign that the vendors and content providers are taking customer acceptability of DRM more seriously: **IBM, Intel, Matsushita Electric Industrial (Panasonic), Microsoft,**

HANA-compliant products, connected with IEEE 1394 (Firewire) will include HDTVs, next-generation DVD players, personal video recorders, set top cable boxes and home theaters. The first commercial products are expected to be available at International CES 2007.

Sony, Toshiba, Disney and Warner Brothers. have funded a new group, the Advanced Access Content System License Administrator. AACS LA released for public review the beta 0.9 versions of the technical specification books for optical media.

Another group, the **High-Definition Audio-Video Network Alliance (HANA)**, founded by **Charter Communications, JVC, Mitsubishi Digital Electronics America, NBC Universal, Samsung and Sun Microsystems**, is working on a design guideline for secure high definition audio-visual networks. In addition to the founding members, **ARM, Freescale Semiconductor** and **Pulse-LINK** have joined HANA as contributing members.

HANA's mission is to create industry design guidelines, utilizing existing technology and specifications that will help enable consumers to:

- View, pause and record 5+ HD channels simultaneously without compromising quality of service;
- View, pause and record HD anywhere in the home with just one set top box;
- Share personal content from PCs to AV devices while keeping protected

content secure;

- Control all AV devices and access content with just a single remote per room; and
- Add any device to the home network with just one cable.

"A major benefit of HANA's initiatives will be the ability for one remote control to manage all of the video equipment that gets connected to a HANA network," said Gerry Kaufhold, principal analyst with **In-Stat**. "This 'one remote control per room' capability is a major breakthrough and presents a tremendous opportunity for consumers to finally be able to have easy access to all their home video content."

In the first half of 2006, HANA plans to work with Advanced Access Content System (AACS), Open Media Commons and other digital rights management technologies to give consumers new flexibility in using content across the entire home network, including moving content across multiple devices such as portable video players. By including copyright detection technology in HANA products, HANA will help consumers to access all of their personal video content while protect-

ing content providers from piracy. HANA's anti-piracy measures will also help enable content providers to make new and exciting HD content available to consumers in a more timely manner.

Additional information about the alliance, its participating companies and membership requirements are available at www.HANAalliance.org.

Stringer admitted there is likely to be a format war between Blu-ray (pushed by Sony) and HD DVD (pushed by Toshiba). "There is no question that a format war is not a good idea, but I don't see what we can do about it," Stringer said.

Toshiba, which seems to be losing to Sony, said it would begin selling a \$500 HD DVD player. Sony executives complained that the only way Toshiba could sell at that low price was with a subsidy from Microsoft, which is putting HD DVD into its Xbox system. Toshiba denies it.

Content

New content offerings abounded.

An area of downloadable content addressed by Stringer centered on the Sony Reader, a new e-book appliance Sony hopes to be shipping by summer. It will hold up to 100 books; new titles can be purchased and downloaded.

Yahoo! Chairman and CEO Terry Semel announced Yahoo! To Go, built on an open platform that lets consumers using a PC, cell phone or TV take all of their information and entertainment wherever they go. Semel also announced Yahoo! Go Mobile, which allows consumers to take their favorite Internet content and services with them on their mobile phones and the Yahoo! Widget Engine, which enables users to run small programs from alarm clocks to weather forecasts on their desktop.

Google Co-Founder and President of Products Larry Page demonstrated prototype applications of the popular Google Earth software, including an in-dash version through a partnership with Volkswagen and a real-time



New set-top box from Scientific Atlanta writes to most DVD formats and handles HD content.

version for cell phones. He also announced Google Talk, an instant messaging service for Gmail, Google Pack, a free software bundle available for download to enhance the workability of PCs, and a mobile search partnership with Motorola.

CBS Corp. President Leslie Moonves joined Page to announce the new Google Video Store and a partnership between CBS and Google that makes CBS and Paramount Studios television shows available for a small fee through the Google Video Store. Google Video Store content can be viewed on downloadable video software on a PC, or on the iPod or Sony PlayStation Portable.

A session on personal healthcare technologies looked at the role of government in healthcare information technology, the need for standards to be put in place to integrate content, and how home healthcare technologies could "bring Big Brother into your home." Moderated by Louis Burns, vice president and general manager, Digital Health Group, **Intel Corp.**, panelists included Cheryl Currid, president, **Currid & Company**; Pramod K. Gaur, Ph.D., president and CEO, **Viterion TeleHealthcare LLC**; and Rebecca Weber, CIO and vice president of information technology, **Meridian Health**.

Motorola announced a partnership with Google to provide consumers access to Google content on Motorola handsets. Under the agreement, Motorola will integrate a Google icon onto select devices that permits one-click access to Google search technology. These "Internet-optimized handsets" will be distributed first quarter of 2006 to select customers worldwide, according to Motorola. The company

also announced an alliance with **Kodak** to work on improving camera-phone technology.

Set-Top Boxes

Scientific-Atlanta's MCP-100 DVR with DVD Recorder/Player received the Consumer Electronics Association's "Best of Innovations" award for Video Components. The device supports most writeable DVD recording formats for standard and high definition content, and will of course play off-the-shelf DVDs and CDs. It respects content protection flags, including 'copy freely', 'copy once', and 'copy never' tags.

The **Diffusion Group** predicts that today's relatively static TV search guide – one tethered to a set-top box and TV – will soon be replaced by a more dynamic, personalized entertainment guide that will serve not only the TV viewing experience, but Internet and mobile video consumption as well. The number of consumers using a "personal entertainment guide" will surge to almost 800 million and create more than \$1.4 billion in global licensing revenue by 2010, according to a Diffusion Group white paper.

"Given the pending shift by both viewers and content providers away from predetermined and static TV subscriptions and toward time-and-place-shifting content consumption, the IPG must respond in kind," said Colin Dixon, author of the white paper and senior analyst with The Diffusion Group. "What will emerge is a 'personal entertainment guide' that capitalizes on many of the techniques pioneered on the Web in the areas of

search, behavior prediction, and distributed computing and thus be more attuned to the viewer's preferences and capable of spanning a multitude of consumer devices, both stationary and portable."

This new white paper, *The IPG Goes New Media*, is available for free download at TDG's website at www.thedif-fusiongroup.com.

Home Networking

The First Mile problem is on the way to being solved. But what about the First Meter?

Historically, consumer electronic devices have stood alone and have been interfaced to external bandwidth directly. However, with the growth of high bandwidth, multiple-computer and multiple-TV households and the desire to share peripherals like printers and storage, there has been a rapid deployment of home networks using wired and wireless in-home technologies. These in-home networks serve the original purpose of facilitating whole-house Internet connectivity. But they fall far short of supporting the demands of delay-sensitive higher bandwidth audio/video traffic.

The next-generation home network will need to evolve in multiple dimensions in order to meet expected future market demands:

- * Wider bandwidth to support multiple HD video, high quality audio, and voice telephony.
- * QoS to support priority assignments to traffic streams.
- * Autodiscovery, self-configuration, and self-healing to facilitate mass-market adoption.
- * Reliability needed to support building automation and security services.
- * Conditional access and rights management to support highly valued entertainment content.
- * Security.

The demands create a huge cost for FTTH deployments – one that is of-

ten overlooked. Smart cities like Loma Linda are requiring that new homes be wired for broadband. But for overbuild FTTH deployments to be economical, existing wiring, usually coax, will often have to be used to carry the signal the last few feet to consumers' TVs.

Recognizing the situation, **Alcatel** joined the Multimedia over Coax Alliance (MoCA). Alcatel's membership in MoCA underscores the company's desire to drive toward standardization for the delivery of these services to the home. The technology underlying MoCA provides a speed of 270 Mbps; field tests in real-world situations (about 300 homes of all types) show MoCA technology net throughputs of more than 100 Mbps to 97 percent of coax jacks without remediation, and 100 percent with a small, inexpensive filter.

MoCA includes **Comcast, Cox Communications, EchoStar, Entropic Communications, Cisco-Linksys, Motorola, Panasonic, Radio Shack, Toshiba and Verizon**. See www.mocalliance.org.

There's clearly money to be made. According to the research group **TDG**, global home networking will grow from 35 million homes in 2004 to over 160 million by 2010. Consequently, TDG also expects the number of network-capable devices will increase dramatically, rising from 108 million today to a staggering one billion Internet and LAN-friendly gadgets in 2010.

Entone Technologies said **Consolidated Communications** is deploying Entone's Hydra IP video gateway to support the telco's IPTV service launch while eliminating set-top boxes. Consolidated Communications is the 15th largest telephone company in the US, with approximately 245,000 access lines throughout Illinois and Texas. It sells a triple-play service bundle.

"Hydra hands-down made the most sense to us," said Matt Hallam, Digital

Video Services (DVS) Product Manager, Consolidated Communications. "Going with a solution that eliminates set-top boxes and uses existing coaxial cabling for home video distribution sets Hydra apart from any other solution on the market."

The Hydra gateway delivers up to three independent television channels to any combination of up to six television sets. In-home video distribution uses a home's existing coaxial cabling; no additional set-top boxes are required at the various televisions throughout the home. Hydra typically is connected to the primary television or home entertainment center, providing video interfaces including coax, composite, s-video and component video. Installation of other televisions simply involves plugging the television into the coax jack.



Entone's sleek Hydra video gateway delivers up to three TV channels to as many as six sets at the same time.

Consolidated is also using Entone's StreamLiner network video recorder based on **HP's** server hardware to support its video on demand. Consolidated Communications' IPTV deployment also includes headend equipment from **Tut Systems, Myrio** middleware from **Siemens SURPASS** Home Entertainment solutions, and content protection from **Verimatrix**. See www.consolidated.com and www.entone.com.

Coaxsys unveiled 200 Mbps Ethernet-over-Coax networking technology at CES, demonstrating the bandwidth boost with **STMicroelectronics**, a supplier of set-top box system-on-chip solutions. Gary Hoffman, Coaxsys VP of Business Development, stated, "TVnet 2X provides a major leap

over the speeds specified by current networking solutions, such as 10/100 Ethernet, HomePlug-AV, and IEEE 802.11n. Like existing 100 Mbps TVnet products, it works over existing TV coaxial wiring - but its higher bandwidth paves the way for the features and functions required by operators delivering IPTV and other high-speed applications within the home.”

Coaxsys has deployed tens of thousands of its TVnet adapters for voice, video, and data with more than sixty service providers. “In addition to meeting Telcos’ need for IPTV networking, TVnet 2X will enable cable MSOs to deploy whole-home, networked PVRs and other IP services,” said Christos Lagomichos, Group Vice President and General Manager of ST’s Home Entertainment Division. For more information see www.coaxsys.com.

Winegard’s newest product, the HOME RUN structured wiring box, was also at CES. Bob Howell, Director Signal Distribution/Off-Air Antenna Business Group, said “Winegard has taken the Triple Play, VoIP, High Speed Broadband Internet and Satellite/Off-Air Video, one step further, by incorporating all the Triple Play services and much more, in one delivery system and bundling them ... on a single existing RG-6 coax cable.”

The box uses **Multilet**’s technology, under an agreement with Multilet US. Because TV and Ethernet use signals at different frequencies, they can be



Stylish ZON controllers are supplied through this router.

combined and transmitted on the same existing cable using the new Multilet system, providing High Speed Internet, local VHF/UHF TV broadcasts and Satellite TV (DBS) programming, even HDTV onto a single existing coaxial cable run.

This offers multi-dwelling unit installers to retrofit an entire MDU project on one existing RG-6 coaxial run. There’s no need to rewire for LAN or Cat-5 to distribute to each room/unit. It is completely transparent to fiber, copper cables, satellite or xDSL broadband. To the consumer, Winegard can now offer a product to easily network their home.

Winegard also announced an agreement with **AMS** to provide Web-enabled real-time remote monitoring of an entire MDU IP physical signal distribution network for entire properties, single buildings or an individual user’s IP network. AMS will also provide customized Triple Play design options for each property and attractive revenue sharing programs for MDU owners. Access Winegard at www.winegard.com, the product’s distributor (**ComponexX**) at www.componexx.com and AMS at www.ams-llc.com.

Oxmoor Corporation showed ZON Audio, an all-digital whole house audio system. A complete ZON Audio system was installed in the NextGen Demonstration Home located in the CES Central Plaza at the Las Vegas Convention Center. ZON is 100 percent digital, end-to-end. Even when the input is analog, the sound is converted to a digital signal on the front end.

Klipsch Audio Technologies, www.klipsch.com, is the worldwide

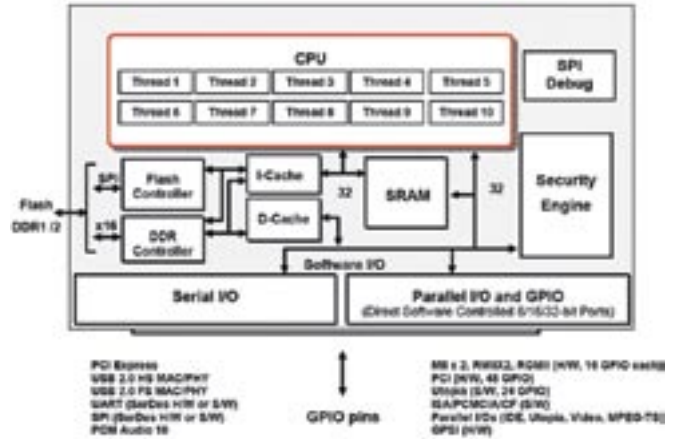

Block diagram shows the role of Ubicom’s StreamEngine 5000 in a home network. Devices like this improve within-home QoS, helping assure that programming coming in through a fiber pipe will be distributed properly.

distributor.

Control4 offers both wired and wireless IP-based products that use the existing home network to deliver benefits to everyday consumers, which were previously only available to the luxury new construction market. Its Wi-Fi Control4 Speaker Point and its Mini Touch Screen “are redefining the home automation market by introducing products that are affordable, easy to install, easy to use and are part of a standards-based solution,” said Will West, Chief Executive Officer of Control4. The Control4 Speaker Point receives digital audio, converting and playing music through an integrated 50 watt per channel digital amplifier. The Control4 Mini Touch Screen combines the functionality of a full-sized touch screen with a remote audio decoder, into a compact wall mounted or tabletop device.

Last spring, the company began shipping its wired and ZigBee (IEEE 802.15.4) wireless products for home control. The addition of Wi-Fi enabled products, provides users with a flexible solution. The Control4 Speaker Point and Mini Touch Screen list for \$449 and \$799 respectively. See www.control4.com for details.

Adding QoS to bandwidth, several companies offered solutions. One of

the most mature was from **Ubicom**. Its StreamEngine 5000 can stream HDTV feeds on the chip rather than in software, and VoIP calls as well. See www.ubicom.com.

HomePlug Resurgence

Home Automation, Inc. (HAI), which makes integrated security and home automation products, introduced an upgrade to its Omni II home automation controller, the Omni IIe. The Omni IIe has all of the functions and capabilities of the Omni II, including security, telephone access, temperature and lighting control, but now has built-in Ethernet connectivity and three built-in serial ports. The Omni IIe can be accessed over the home network and over the Internet without having a computer running at the house. It also

controls high-definition video and audio by simply plugging the product into a convenient electrical outlet." Initial consumer products using the chip are expected during the second quarter of 2006. See www.intellon.com.

Intellon Corporation, which builds HomePlug-compatible integrated circuits for home networking, networked entertainment and broadband over powerline applications, demonstrated an integrated circuit chip based on the new 200 Mbps HomePlug AV specification. The bandwidth is more than enough for multiple high-definition video streams to be distributed over existing home powerlines, coaxial cable or other wiring with whole-house coverage, low latency and robust Quality of Service (QoS).

The chip includes built-in 128-bit AES encryption and is compatible with products based on the HomePlug 1.0 powerline communications specification, including Intellon's HomePlug 1.0 and 1.0 with Turbo ICs. It is based

definition video and audio by simply plugging the product into a convenient electrical outlet." Initial consumer products using the chip are expected during the second quarter of 2006. See www.intellon.com.

Intellon and **Wisair**, a provider of Ultra Wideband (UWB) and Wireless USB (WUSB) chipset solutions, collaborated on a demonstration of distribution of HDTV streams throughout the home. It used Intellon's older HomePlug technology together with Wisair's 480 Mbps UWB; the powerline was the network backbone and the UWB a short-range wire replacement solution. See www.wisair.com.

Samsung Electronics unveiled its "Digital Living Network" using power line communications technology designed in partnership with **Design of Systems on Silicon (DS2)**. Their demo featured consumer electronic devices sharing digital content through a PLC AV (Audio-Visual) Home Network; several appliances with embedded DS2's latest-generation technology enable networking speeds up to 200 Mbps as soon as they are plugged into the wall power outlets.

For the products being demonstrated at CES, DS2 and Samsung worked together to embed DS2's chipset technology into AV home devices, including high-definition televisions, DVD players/recorders with built-in hard disk drives, cameras, and digital media server PCs. These devices were connected via PLC to a Wi-Fi network, allowing connection to a wireless notebook and printer to demonstrate the ease of interoperability and networking with just the electrical outlets in the home.

Two industry groups, the **Universal Powerline Association (UPA)** and the European Union consortium **OPERA (Open PLC European Research Alliance)**, have adopted DS2 technology in support of multi-vendor standard certified product. For more information, see www.ds2.es.



Omni IIe from HAI controls a sophisticated home network through the electrical wiring.

simplifies wiring to in-home computers, because no serial cable is needed. Included with the Omni IIe controller is a Powerline Interface Module for HAI's new UPB based lighting control system; it plugs directly into the third built-in serial port without requiring any port expanders.

Positioned a bit closer to the company's flagship OmniPro II, the IIe provides advanced features for homes that don't need as many zones, lighting controls, thermostats and the au-

on the worldwide HomePlug AV specification approved by the HomePlug Powerline Alliance last year. Sponsor members of the Alliance include Comcast, **Earthlink**, Cisco-Linksys, **General Electric**, Intel, Motorola, RadioShack, **Sharp** and Sony.

Said Charlie Harris, Chairman and CEO of Intellon Corporation, "With the INT6000, any consumer electronics product, PC, broadband modem, set-top box, personal video recorder or flat-screen display can share high

The next-generation home network will need to evolve in multiple dimensions in order to meet expected future market demands.

Michimasa Arimaki, Director of the **Panasonic Research and Development Corporation of North America**, discussed Panasonic's new high bandwidth home wiring solution, the HD-PLC chip, at a "New Internet Consumer Electronics" panel hosted by **IPv6 Summit** (Version 6 is the latest iteration of IP, the Internet's "operating system"). IPv6 Summit is a subsidiary of **Innofone**

PMA Technology Suite X9 introduced the world's First UWB Image Transfer Board for Cameras; and TV Viewer. It transmits photos and video to HDTV or set-top boxes without the need of a PC or network. There's a CWPD (Camera Wireless Printing Device) 802.11g printer accessory (internal in-printer cards and external USB) that enables wireless printing between cameras and printers. www.fotonation.com

Services

CinemaNow, a digital video aggregator and distributor, and **Oregon Networks**, a supplier of media browsing and streaming software, announced a customizable service enablement framework that device manufacturers can use to incorporate the CinemaNow service on consumer devices with broadband connectivity. The service delivery model is similar to the telco IPTV scenario, where digital content arrives directly to the television without an interim download on a personal computer.

Oregon's Media Browser will enable CinemaNow on-demand and subscription video services via a proposed Consumer Electronics Association

(CEA) standard CEA-2014, spearheaded by **Philips**, Intel and Samsung. The content is delivered directly to a networked consumer electronic device over DSL, FTTH or wireless network connectivity, protected with Microsoft Windows Media Digital Rights Management 10 and accessed via XHTML web browsing technology provided by Oregon.

"Delivery of CinemaNow directly to consumer devices is an important milestone in the content convergence market.... The flexible architecture of Oregon Media Browser enables web-based content providers to deliver their services across a variety of devices on a par with the PC-centric offering, without losing the quality and responsiveness of the user interface and media streaming," said Reed Hinkel, Oregon's VP of Business Development in the Americas.

CinemaNow (www.cinemanow.com) offers content from a library of more than 7,500 new and classic movies, television programs, music concerts and music videos from **20th Century Fox, ABC News, Disney, HDNet, Lions Gate, MGM, Miramax, NBC Universal, Sony, Sundance Channel, Warner Bros.** and more than 250 other licensors via downloading or streaming. Oregon is privately owned, with headquarters in London and branch offices in USA, Japan and Taiwan. See www.oregon.net

DAVE.TV (there's no guy named Dave – it's an acronym for Distributed Audio Video Entertainment) is the first Internet-based television delivery system that lets Dad watch football in the den in HDTV, Mom watch cook-

ing shows on a PC in the bedroom, Sis watch and listen to music videos on her portable multimedia device, and still let Granny watch independent films on her cell phone. Multiple platforms, unlimited users, all on one bill.

DAVE.TV's new IPTV platform, unveiled at CES, also enables the viewer to immediately respond to or alter programming.

Gadgets

Despite the hype, no life-changing gadgets appeared at this year's CES. There were, however, many new products that should expand consumer demand for digital content, beyond the "early adapters" that tantalize the marketplace.

Some companies are making big bets on the recording media of the future, assuming that broadband connections and digital video demand it. **InPhase Media** has been pushing technology that records up to 300 GB on its "H-ROM" media, a DVD-size "holographic" disk using the same 630 nanometer red laser wavelength now used in conventional CD and DVD recorders. The capacity would be three times that of Blu-ray and five times that of the HD DVD. But the technology will take a long time to reach the hands of consumers. InPhase does not expect to even deliver a holographic product for professional archive applications until late 2006. The media will come from **Hitachi Maxell Ltd.** The data transfer rate target is 20 megabytes per second (160 Mbps), more than enough for high-definition television.

InPhase has been shipping its Tapestry HDS4000 media since late 2005 to companies developing consumer holographic devices, however. The will be made in several different form factors, from postage stamp to credit card size; the latter could hold several high definition movies. See www.inphase-tech.com.

Griffin Technology Inc., creator of all things iPod, announced Tune-

Center docking and charging station for iPods. Attach it to a television and stereo for viewing photos, watching downloaded video, listening to iPod music or Internet radio. With the included 14 button remote, TuneCenter turns the iPod into a complete Home Media Center. It can display iPod playlists, song information and images on a TV screen. People were talking about using it to present images of PowerPoint slides. It includes Ethernet and Wi-Fi connectivity. The price is \$99.99 with shipping to start in March. See www.griffintechology.com.

Spotwave Wireless showed Zen, an intelligent wireless coverage product that dramatically improves indoor wireless reception for spaces up to 2500 square feet. Designed for home and small offices, Zen improves indoor signal strength of cell phones, PDAs and other mobile devices across the entire PCS band (1900 MHz). The result is clear voice quality with maximum data throughput for cell phones, PDAs and 3G enabled devices. It is an ideal solution for professional wireless subscribers frustrated by the inability to use wireless devices indoors due to poor signal strength.

Until now Spotwave has been only in the commercial-grade coverage market, selling systems designed for medium-to-large spaces (25,000 square feet and higher). Zen is the only network-protecting, intelligent coverage system available for small office home office and residential space.

Zen should be available for pur-

chase in the second quarter of 2006 through the company's website and via retail and channel partners. The Zen PCS system is \$399. More information is available on the company website at www.spotwave.com/zen. It supports CDMA, GSM, EVDO, UMTS (voice and data) in North America, in the 1900 MHz band digital cell phone use here.

BuLogics, producer of innovative home automation products, announced release of BaseCamp, a Z-Wave enabled system that delivers comprehensive home automation that consumers can configure themselves through their television, without the complications of a computer or the expense of a custom installer. With BaseCamp's handheld remote, consumers can then control their home from anywhere in the house.

Consumers simply plug BaseCamp directly into their television and input their preferred settings according to their personal lifestyle. BaseCamp's intuitive television interface utilizes the colorful grid scheme that consumers are already familiar with from their basic cable TV system. Consumers navigate through the setup menu with a small, handheld remote control called Lantern.

The Lantern remote is a pocket-sized handheld device that also acts as a standalone component. With its own display screen and navigational wheel, the Lantern remote can call up personal home control settings from anywhere in the house. Lantern uses the Z-Wave wireless technology

standard, so settings for household lights, electronic timers, HVAC, garage doors and window shades can be called up from multiple rooms away. The system is compatible with any device that is Z-Wave enabled, including products from Z-Wave Alliance partners **Honeywell, Leviton**, Motorola, Panasonic, **Sylvania and Techniku**.

The complete BaseCamp system, including the Lantern handheld device, retails for \$399 in the U.S. See www.bulogics.com. The Z-Wave Alliance for wireless home control products is at www.Z-WaveAlliance.com.

Accelerated Technology (a division of **Mentor Graphics**) and embedded software provider **Blue Peach** announced they are now providing the only embedded Real-Time Operating System (RTOS)-based Networked Attached Storage (NAS) Media Server for Intel-based digital home applications. This combined technology provides developers with a platform to deploy embedded digital content-aware applications quickly and easily.

The technology is licensed royalty-free. Licenses for the Nucleus software begin at \$12,495. The Blue Stream Media Server is available in various configurations and starts as low as \$20,000. For more information, contact Accelerated Technology at 800-468-6853 or info@acceleratedtechnology.com or www.mentor.com.

Verizon offered an interesting new initiative, selling Verizon-branded broadband network equipment at many of the retail outlets that already sell Verizon DSL.

To start, the items themselves are being supplied by Belkin. Only the box (and maybe the price) changes. But down the road, it could help Verizon assure that in-home fiber accessories are available for consumers installing their own home networks. **BBP**

Some companies are making big bets on the recording media of the future, assuming that broadband connections and digital video demand it.

About the Author

Contributing editor Robert Calem contributed to this staff report.